

(Tolerance: ± 0.1)
(P.C.B thickness $t=1.6$)

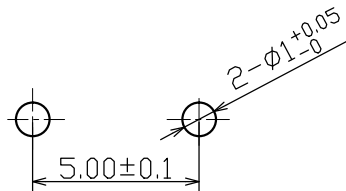

ITEM	PART NAME	MATERIAL	COLOR
1	BUTTON	POM	BLACK
2	SILICA GEL	SILICA GEL	
3	COVER	PBT	BLACK
4	SPRING	SUS	
5	BASE	PA66	BLACK
6	TERMINAL	SILVER PLATE BRASS	

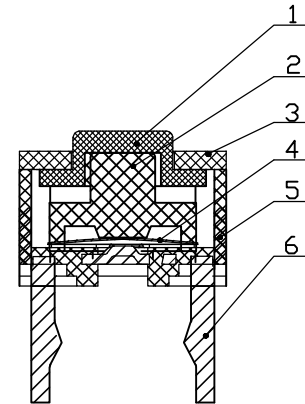

Rating	6VDC 50mA
Contact Resistance	500m Ω Max
Insulation Resistance	50M Ω Min
Dielectric Voltage	250VAC 60 \pm 5S
Endurance	3,000,000 cycles
Operating Force	70 \pm 15gf
Pre-travel	0.35 \pm 0.2mm