

ITEM	PART NAME	MATERIAL	COLOR
1	BUTTON	PBT	BLACK
2	SILICA GEL	SILICA GEL	
3	COVER	PBT	BLACK
4	SPRING	SUS	
5	BASE	PA66	BLACK
6	TERMINAL	SILVER PLATE BRASS	

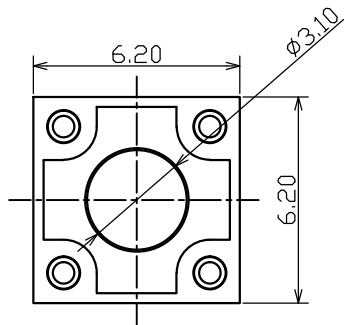

(Tolerance:  $\pm 0.1$ )  
(P.C.B thickness  $t=1.6$ )

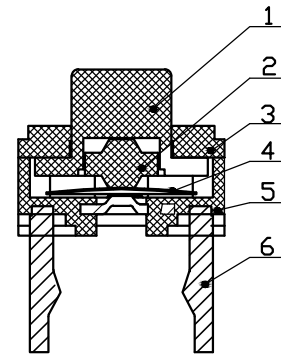
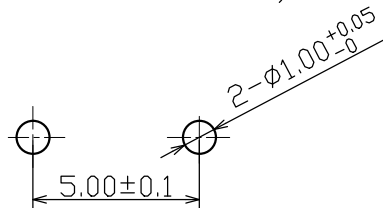

Rating	6VDC 50mA
Contact Resistance	500mΩ Max
Insulation Resistance	50MΩ Min
Dielectric Voltage	250VAC 60±5S
Endurance	3,000,000 cycles
Operating Force	80±10gf
Pre-travel	0.35±0.2mm